

Panel Mounting Design / DKB-XXP series

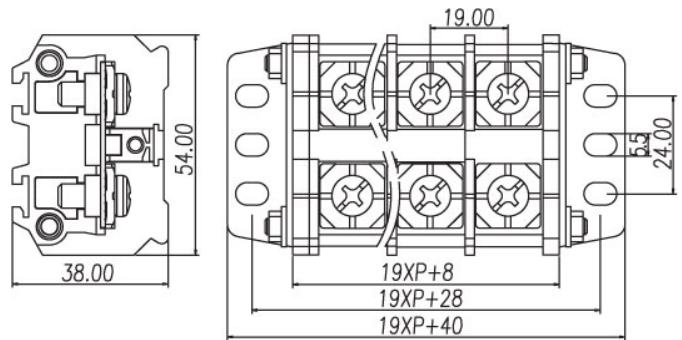

**DKB60-XXP**



**Pitch: 19mm**

Approval	<b>UL</b>		<b>FW2</b>
Technical Data	UL	IEC	
Rated Voltage	600V		
Rated Current	65A		
Applicable Wire (AWG)	18-6		
Torque (Lb-in)	26.6		
Screw	M6		
Housing Material	PC		

**TEL:** +886-2-2908-0614

**FAX:** +886-2-2908-8549

**E-mail:** [infor@dinkle.com.tw](mailto:infor@dinkle.com.tw)